

MUSA COMFORT AIR

Componenti Struttura Esterna / External structure components / Bauteile Aussenkorpus / Composants structure externe / Componentes estructura externa

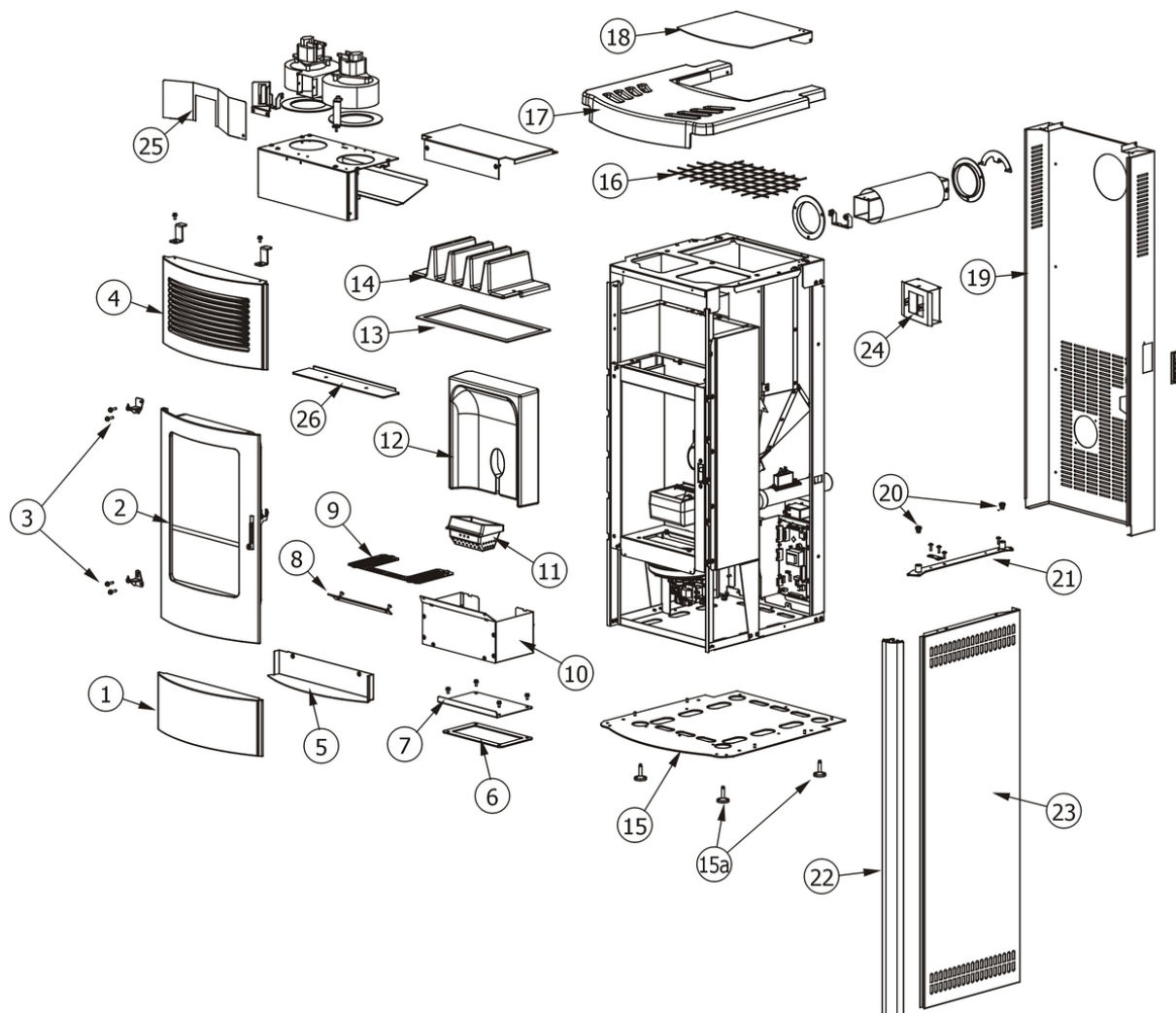

N°	Codice/Code	Descrizioni / Description / Beschreibung / Description / Descripción
1	41300901000V	Tamponazione inferiore / Lower filler / Untere Stopfung / Plaque inférieure / Tapa inferior
2	41300801550	Porta finita completa / Complete finished door / Komplette Tür / Porte finie complète / Puerta completa
3	41200904061	Cerniera superiore e inferiore (2 pz) / Upper and lower hinge (2 pcs) / Oberes und unteres Scharnier (2 Stck) / Charnière supérieure et inférieure (2 pcs) / Bisagra superior e inferior (2 pz)
4	413008016V	Griglia uscita aria in ghisa / cast iron Air outlet grille / Gusseisernes Gitter Warmluftaustritt / Grille de sortie air chaud en fonte / Rejilla salida aire de arrabio
5	41400908230V	Riparo sotto la porta fuoco / Door protection / Schutz unter der Tür / Protection sous porte / Resguardo abajo puerta
6	418008025	Guarnizione / Gasket / Dichtung / Joint / Junta
6	4180080251	Kit 50 guarnizioni / Kit 50 gaskets / Bausatz 50 Dichtungen / Kit 50 joints / Kit 50 juntas
7	41400906330V	Tappo ispezione vano fumi / Smoke compartment inspection plug / Inspektionsdeckel Rauchabzug / Clapet inspection compartiment fumées / Tapón inspección compartimento humos
8	41400907830V	Deflettore cenere / Deflector / Aschenleitblech / Déflecteur / Deflector
9	41400906610V	Griglia focolare / Fire box grille / Feuerstellenrost / Grille foyer / Rejilla hogar
10	41400958130V	Cassetto cenere / Ash drawer / Aschenkasten / Tiroir à cendres / Cajón ceniza
11	413008003	Braciere completo in ghisa / Cast iron complete grate / Kompletter Brennertopf aus Gusseisen / Brasero complet en fonte / Brasero completo de arrabio
12	43650151	Schiena in Alutec® / Alutec® back / Rückwand aus Alutec® / Fond en Alutec® / Parte trasera en Alutec®
13	41800802600	Kit 50 guarnizioni / Kit 50 gaskets / Bausatz 50 Dichtungen / Kit 50 joints / Kit 50 juntas

13	41800802601	Guarnizione / Gasket / Dichtung / Joint / Junta
14	413008001	Scambiatore in ghisa / Cast iron exchanger / Gusseiserne Wärmetauscher / Echangeur en fonte / Intercambiador en arrabio
15	41400909740V	Basamento / Base / Basis / Base / Base
15a	4120618	Piedini di appoggio (4 pz) / Support feet (4 pcs) / Einstellfüße (4 Stck) / Vérins d'appui (4 pcs) / Pies de apoyo (4 pz)
16	41400904100	Griglia protezione serbatoio / Hopper protection grille / Schutzgitter Pelletbehälter / Grille de protection réservoir / Rejilla de protección depósito
17	41300900900V	Top grigio in ghisa / gray cast iron Top / Top Grauguss / Dessus fonte grise / Top gris de arrabio
18	41400910160	Coperchio serbatoio pellet / Pellet hopper cover / Deckel Pelletbehälter / Couvercle réservoir pellet / Tapadera depósito pellet
19	41400910061	Schiena esterna in acciaio / External back in steel / Aussenrückwand aus Stahl / Fond extérieur en acier / Panel trasero externo de acero
20	4120180	Gommini paracolpi (4 pz) / Rubber bumpers (4 pcs.) / Schlagschutzgummi (4 Stck) / Pièces caoutchouc antichoc (4 pcs) / Cauchitos anti-golpes (4 pz)
21	41400910240V	Staffa bloccaggio SX / L. Superior Bracket / Oberer LI. Bügel / Étrier supérieur G. / Abrazadera superior IZDO
21	41400910340V	Staffa bloccaggio DX / R. Superior Bracket / Oberer RE. Bügel / Étrier supérieur D. / Abrazadera superior DCHO
22	41200804950	Montante anteriore / Frontal vertical rod / Vordere Montageleiste / Montant antérieur / Montante anterior
23	6909016	Rivestimento completo White metal / Complete White metal cladding / Komplette Verkleidung White metal / Habillage complète White metal / Revestimiento completo White metal
23	6909017	Rivestimento completo Dark metal / Complete Dark metal cladding / Komplette Verkleidung Dark metal / Habillage complète Dark metal / Revestimiento completo Dark metal
23	6909018	Rivestimento completo Silver metal / Complete Silver metal cladding / Komplette Verkleidung Silver metal / Habillage complète Silver metal / Revestimiento completo Silver metal
23	6909019	Rivestimento completo Bordeaux metal / Complete Bordeaux metal cladding / Komplette Verkleidung Bordeaux metal / Habillage complète Bordeaux metal / Revestimiento completo Bordeaux metal
24	41400910500V	Diffusore aria calda / Hot air diffuser / Warmluftdiffusor / Diffuseur air chaude / Difusor aire caliente
25	41400916930V	Griglia ventialore aria / Air fan grille / Gitter Luftgebläse / Grille ventilateur air / Rejilla ventilador aire
26	41400939231	Deflettore focolare in acciaio / Steel fire box deflector / Feuerstelleleitblech aus Stahl / Déflecteur foyer en acier / Deflector hogar en acero

MUSA COMFORT AIR

Porta fuoco / Fire door / Feuertür / Porte foyer / Puerta hogar

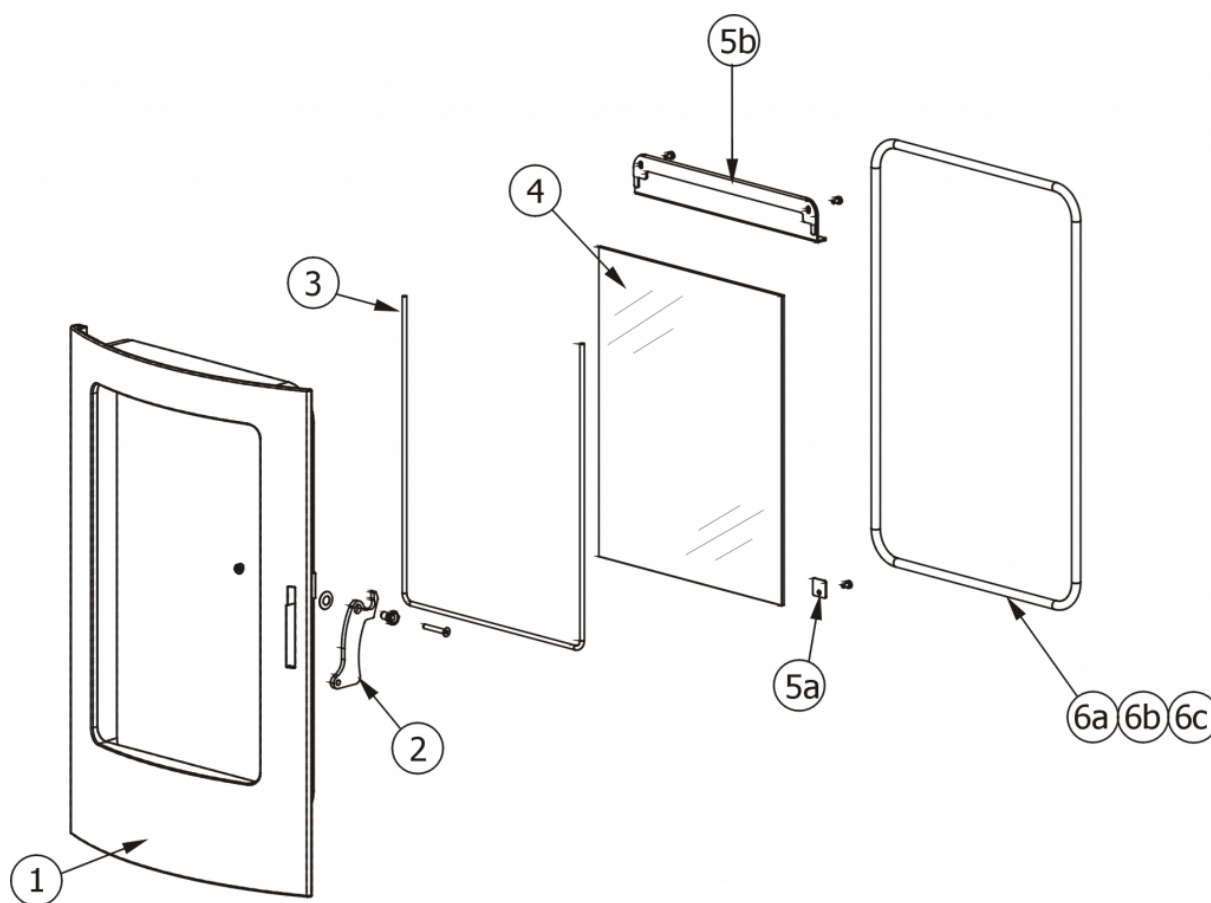

N°	Codice/Code	Descrizioni / Description / Beschreibung / Description / Descripción
1	413008015V	Telaio porta fuoco / Fire door frame / Feuertürrahmen / Cadre porte foyer / Armazón puerta de arrabio
2	41400908660	Maniglia completa / Complete handle / Kompletter Griff / Poignée complète / Tirador completo
3	4120106	Guarnizione a nastro fireglass / Fireglass tape gasket / Banddichtung Fireglass / Joint ruban Fireglass / Guarnición a cinta Fireglass
4	41700900660	Vetroceramico con guarnizione / Glass with gasket / Glaskeramikscheibe mit Dichtung / Vitrocéramique avec joint / Cristal cerámico con guarnición
5a	41401077430	Staffe di fissaggio vetroceramico (4 pz.) / Pyroceram fastening brackets (4 pcs.) / Befestigungsbügel Glaskeramik (4 Stck.) / Étrier de fixation vitrocéramique (4 pz.) / Abrazaderas de fijación vidrio cerámico (4 piezas)
5b	41400908530V	Deflettore porta / Door deflector / Tür Leitblech / Déflecteur de la porte / Deflektor de la puerta
6a	4120103A	Cordino fibroceramico Ø 10 mm (5 mt.) / Ceramic fibre cord Ø 10 mm (5 m) / Keramikfaserschnur Ø 10 mm (5 m) / Cordon en fibre céramique Ø 10 mm (5 m) / Junta a cuerda de fibra cerámica Ø 10 mm (5 m)
6b	4120103B	Cordino fibroceramico Ø 10 mm (50 mt.) / Ceramic fibre cord Ø 10 mm (50 m) / Keramikfaserschnur Ø 10 mm (50 m) / Cordon en fibre céramique Ø 10 mm (50 m) / Junta a cuerda de fibra cerámica Ø 10 mm (50 m)
6c	41201031	Kit sostituzione cordino (cordino+silicone) Ø 10 mm / Cord replacement kit (cord + silicone) Ø 10 mm / Schnur austauschsatz (Schnur+Silikon) Ø 10 mm / Kit remplacement cordon (cordon + silicone) Ø 10 mm / Kit sustitución junta a cuerda (junta a cuerda+silicón) Ø 10 mm

MUSA COMFORT AIR

Componenti interni meccanici ed elettronici / Electronic and mechanic internal parts / Interne mechanische und elektronische Bauteile / Composants internes mécaniques et électroniques / Componentes internos electrónicos y mecánicos

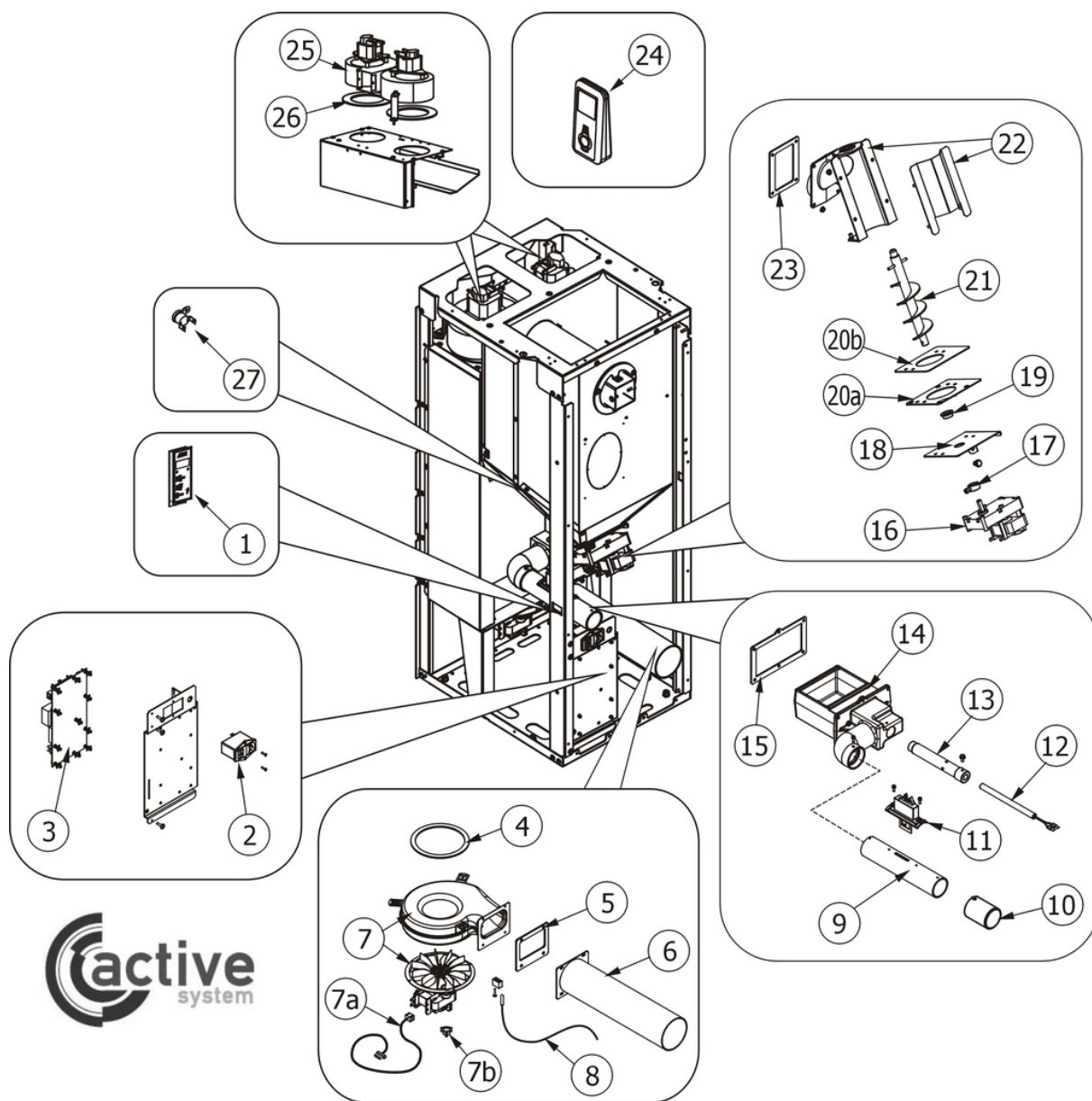

N°	Codice/Code	Descrizioni / Description / Beschreibung / Description / Descripción
1	41450900700	Pannello di emergenza / Emergency panel / Notfalldisplay / Tableau de secours / Panel d'emergencia
1	41450902500	Cavo flat / Flat cable / Flat-Kabel / Cable flat / Cable flat
1	41801499750	Kit 868 / Kit 868 / Kit 868 / Kit 868 / Kit 868
2	4160459	Pulsante accensione / On/Off button / Zündungstaste / Touche d'allumage / Botón encendido
3	41450907601	Scheda madre / Motherboard / Hauptplatine / Carte mère / Tarjeta madre
3	41801499750	Kit 868 / Kit 868 / Kit 868 / Kit 868 / Kit 868
4	41801002600	Guarnizione adesiva voluta fumi / Adhesive gasket smoke volute / Haftendichtung Rauchvolute / Joint adhesive volute fumées / Junta adhesiva voluta humos
4	41801599850	Kit 50 guarnizioni / Kit 50 gaskets / Bausatz 50 Dichtungen / Kit 50 joints / Kit 50 juntas
5	418008030	Guarnizione / Gasket / Dichtung / Joint / Junta
6	416008010	Tubo uscita fumi / Smoke outlet pipe / Rohr Rauchabzug / Tuyau sortie fumées / Tubo salida humos

7	41451003202	Ventilatore aspirazione fumi / Smoke exhausted fan / Rauchabsauggebläse / Ventilateur aspiration fumées / Ventilador aspiración humos
7	41801102500	Guarnizione / Gasket / Dichtung / Joint / Junta
7a	4160477	Cavo ENCODER / ENCODER cable / Drehzahlmesser kabel / Câble ENCODER / Cable ENCODER
7b	41451209300	Encoder per ventilatore fumi marchi LN2/SIT / Encoder for LN2/SIT smoke fan / Encoder für LN2/SIT Rauchgasgebläse / Encoder pour ventilateur des fumées marques LN2/SIT / Encoder para ventilador humos marcas LN2/SIT
8	41450901800	Sonda fumi Active System / Smoke sensor Active System / Rauchgasfühler ACTIVE SYSTEM / Sonde fumées ACTIVE SYSTEM / Sonda humos Active System
9	41200901200	Tubo ingresso aria / Air inlet pipe / Lufteringangsrohr / Tuyau entrée air / Tubo entrada aire
10	41401036100	Filtro antipolvere / Anti-dust filter / Staubschutzfilter / Filtre antipoussière / Filtro de protección polvo
11	41451205000	Sensore aria completo / Complete air sensor / Kompletter Luftfühler / Capteur air complet / Sensor aire completo
12	41450905000	Candeletta accensione pellet / Pellet ignition sparkplug / Zündkerze Pelletzündung / Bougie d'allumage pellet / Bujía encendido pellet
12	41801599550	Kit 50 candelette / 50 Sparkplugs kit / Bausatz 50 Zündkerzen / Kit 50 Bougies / Kit 50 Bujías
13	41200903900	Condotto candeletta / Sparkplug conduit / Zündkerzenkanal / Conduit bougie / Conducto bujía
14	414008043	Tasca braciere in ghisa / Combustion pot container / Brenntopfkasten aus Gusseisen / Récipient braséro / Contenedor brasero
14	41401069141V	Tasca braciere / Combustion pot container / Brenntopfkasten / Récipient braséro / Contenedor brasero
15	418008027	Guarnizione / Gasket / Dichtung / Joint / Junta
16	4160278	Motoriduttore 1,5 RPM / Reduction motor 1,5 RPM / Getriebemotor 1,5 RPM / Motorréducteur 1,5 TPM / Motorreductor 1,5 RPM
17	4120398	Connettore motoriduttore-coclea / Reduction motor-feed screw connector / Verbindung Getriebemotor-Schnecke / Connecteur motorréducteur-vis sans fin / Conector motorreductor-cóclea
18	41400944351	Base della coclea / Feed screw base / Untergestell der Förderschnecke / Base de la vis sans fin / Base de la cóclea
19	4120614	Boccola grafitata (2 pz) / Etched bush (2 pcs) / Graphitbuchse (2 Stck) / Bride graphitée (2 pcs) / Brida grafitada (2 pz)
20a	4120615	Guarnizione base della coclea / Feed screw base gasket / Dichtung Untergestell der Förderschnecke / Joint pour la base de la vis sans fin / Junta base de la cóclea
20b	41400903310	Flangia condotto coclea / Base of feed screw conduit / Untergestell Rohrleitung der Förderschnecke / Base du conduit de la vis sans fin / Base de conducto de la cóclea
21	41200901040	Coclea di caricamento pellet / Pellet feed screw / Pelletsförderschnecke / Vis sans fin pour chargement du pellet / Cóclea de carga pellet
22	41401077540V	Condotto della coclea / Conduit of feed screw / Rohrleitung der Förderschnecke / Conduit de la vis sans fin / Conducto de la cóclea
24	41450901500	Telecomando / Remote control / Fernbedienung / Télécommande / Mando a distancia
24	41451106000	Telecomando / Remote control / Fernbedienung / Télécommande / Mando a distancia
24	41801499750	Kit 868 / Kit 868 / Kit 868 / Kit 868 / Kit 868
23	418008029	Guarnizione / Gasket / Dichtung / Joint / Junta
25	41451002903	Motore ventilatore portata 170 m3/h / Fan motor capacity 170 m3/h / Gebläsemotor Leistung 170 m3/h / Moteur ventilateur débit 170 m3/h / Motor ventilador caudal 170 m3/h
27	412007004	Clickson 110°C / Clickson 110°C / Clickson 110°C / Clickson 110°C / Clickson 110°C
26	418008018	Guarnizione ventilatore / Fan gasket / Dichtung des Gebläses / Joint du ventilateur / Junta ventilador